

VENTILATION SOLUTIONS FOR SOCIAL HOUSING

HELPING TO CREATE HEALTHY, ENERGY EFFICIENT HOMES



COMMERCIAL



RESIDENTIAL



RMI



MORE THAN 60 YEARS' OF EXPERIENCE

Founded in 1955, Airflow has grown from one man's expertise in fan design and air flow measurement into a thriving international group. Renowned for its innovative approach to new product development and air movement techniques, Airflow can offer you a variety of ventilation solutions to suit your needs.

With our headquarters in High Wycombe, Airflow has subsidiaries in Germany and the Czech Republic and has global distributors from Norway to New Zealand.

Listening to the requirements of our customer enables Airflow's knowledgeable and committed staff to continually develop new and innovative products that raise standards and provide long term, reliable ventilation solutions.



UNITED KINGDOM

High Wycombe (Head Office)

Our founder started the business in 1955, just one mile from the current site, which has been Airflow's headquarters since 1960, co-ordinating our global activities.



GERMANY

Airflow has been serving ventilation products and air measurement devices to the German and European markets for over 50 years. Operating near Cologne, Airflow Germany has their own customer service, sales and technical sales teams.



CZECH REPUBLIC

Founded in Prague over 20 years ago, the Airflow Czech Republic team offer sales and servicing of ventilation products for the Eastern European market.



BETTER VENTILATED HOMES MAKE BETTER LIVES

The requirement for many more affordable homes continues as does the need to improve the quality of the existing housing stock. The Decent Homes Programme has taken great strides in upgrading older dwellings but there is still much to be done.

As we build new and regenerate older dwellings to a higher standard of insulation, so we increase the conditions for dampness and mould growth and an environment with poor indoor air quality to thrive.

Where the UK Government support any retrofit works, it requires these to be done to Publicly Available Specification (PAS) standard. Such standards that exist are PAS 2030:2017, and the new PAS 2035 due out in mid-2019. These are available from BSI. The aim is that by ensuring these standards are followed and adhered to the quality of work improves.



A key element of PAS2035 is the requirement to install effective ventilation in all properties, especially those where insulation measures are introduced.

Furthermore there is a requirement to check the ventilation in all properties and to upgrade the system when it fails to meet the specified criteria.

Therefore producing effective, efficient and compliant ventilation will be an obligation for social housing providers to combat the potentially harmful effects of dampness and mould and reduce the airborne pollutants which can result in a 'Toxic Home'.

UNDERSTANDING THE ISSUES

A highly respected report concluded that 40,000 deaths a year can be linked to air pollution.

Toxic Home Syndrome can develop Allergies,
Alzheimer's and strokes.

The health problems resulting from exposure to air pollution have a high cost to people who suffer from illness and premature death, to our health services and to business.

Source: The Royal College of Physicians: Every Breath We Take: the lifelong impact of air pollution April 2016

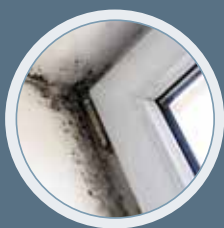

WHAT IS 'TOXIC HOME'?

If you live in an air tight home with poor air quality, you and your family could be at risk of headaches, long lasting colds and bronchitis as well as chronic asthma and allergies.

15.3 million homes in the UK are at risk of Toxic Home Syndrome from the build-up of moisture and airborne pollutants, Volatile Organic Compounds (VOC's) within the air in your home.

Poor indoor air quality can lead to dampness and mould developing and damaging the fabric of the home and the air we breathe.





LANDLORDS LEGAL RESPONSIBILITIES

Creating a healthy, well ventilated environment is not just common sense, it is part of a landlords "Duty of Care" to their tenants well being.

The Housing Act and The Home Standard are just two examples of legislation on the statute books with embodied elements requiring systematic assessments of the condition of residential premises to ensure a dwelling is fit for human habitation.

Under the Defective Premises Act 1972, landlords are responsible for ensuring the habitability of rented accommodation. The landlord must perform any maintenance work that is deemed necessary for keeping the dwelling habitable for the tenant.

The Landlord and Tenant Act of 1985 does state that "the house shall be regarded as unfit for human habitation" if, and only if, it is so far defective in one or more of the following:

In that list VENTILATION appears as does FREEDOM FROM DAMP amongst other items that would deem the property unfit.

The above act has now had a further amendment by way of the Homes (Fitness for Human Habitation) Act 2018, this comes into force on the 20th March 2019.

The Bill will help private and social renter's, by giving them the right to take their landlord to court over unfit and unsafe conditions like the above in their home.

HEALTHY HOMES

Health is defined by the World Health Organisation as "a state of complete physical, mental and social well-being".

The importance of building and crucially, maintaining homes to provide a safe, comfortable living environment and to protect the fabric of the dwelling is paramount.

ENSURE THE CORRECT STANDARDS ARE FOLLOWED

When choosing a contractor it is important that they carry out any works to the correct standards. In lots of instances when Energy Efficiency Measures (EEM) are installed and the contractor does not work to the PAS standards then the EEM may not be effective or they may cause other problems within the dwelling. Choosing a contractor who is familiar with the Standards PAS 2030 2017 and PAS 2035, will go some way to ensure that you will not have condensation or moisture issues caused by poor or incorrect ventilation.

TAKING CARE OF VENTILATION IN SOCIAL HOUSING SINCE 1969

Designed to meet the growing demand for a quality ventilation solution, particularly for the council housing build programmes of the 1970's, the LOOVENT was created.

Quiet, reliable and effective it has become the by word for social housing ventilation. With more than two million installed it is effective today in protecting your assets and clearing the air for tenants and owners, as it ever was. The current LOOVENT has a smaller energy consumption and is quieter, whilst still giving a class leading performance.

MORE THAN TWO MILLION SOLD

1969



1982



1991



2015



2024



SOLUTIONS AVAILABLE TO MEET THE BUILDING REGULATIONS



Intermittent extractor fans – designed more with budget in mind than performance



Intermittent extractor fans – designed with performance and style in mind as well as reducing heat loss and backdraught



Intermittent extractor fans – designed to perform and be Quiet using a small amount of energy, the quietest fan available that performs (beware of silent imitations)



Constant trickle fans – Choices available for through the wall or challenging duct runs



Heat recovery ventilation – solutions from single room units to whole house units, and can be used in conjunction with extractor fans



Retro - ducting means you can have central extraction without the need to conceal the ducting



If the dwelling does not have space for a central unit then Airflow manufacturers a unit that can go above your hob and also carry out the function of a cooker hood



AIR ACADEMY & TRAINING CENTRE

Airflow is proud to welcome customers to the state-of-the-art Air Academy training facility at the Airflow UK Head office in High Wycombe.

This 500m² facility is designed to educate, inform and inspire all visitors. More than just an experience centre, the Air Academy is an elite training facility that is able to offer CIBSE approved CPD seminars.

One of our experts will happily provide you with a tour of the academy which showcases Airflow's wide range of innovative products. You'll be guided through the history of ventilation and be able to see the first inclined manometer to go into commercial production, as well as the first Internet-controllable MVHR units in the UK.

To arrange a visit to the Air Academy, please contact your Account Manager or alternatively contact Airflow on: **+44 (0)1494 525252** or e-mail info@airflow.com.



TRAINING SERVICES

Airflow offers on-demand CPD sessions for architects, specifiers, and M&E consultants at the Air Academy or a location of your choice. These sessions can also be hosted online. Scan the QR code to find out more and to book onto one of these highly popular sessions at a date, time and location convenient to you.

CIBSE APPROVED CPD

Understanding UK Building Regulations Relating to Residential Mechanical Ventilation with Heat Recovery.

Understanding Mechanical Ventilation with Heat Recovery for Commercial Applications.



Book your CPD



**Residential MVHR
CIBSE CPD Course**



**Commercial MVHR
CIBSE CPD Course**

RESPONSIBLE MANUFACTURING

ISO 9001 Quality Matters

Airflow is dedicated to delivering innovative, high-quality products with in-built reliability and proudly holds the ISO 9001:2015 certification. This ensures that every product we produce is rigorously tested and meets stringent international standards, assuring our customers of its long-lasting durability over years of operation.



ISO 14001 Environmental Matters

Airflow is dedicated to minimising its environmental impact and has successfully achieved the ISO 14001:2015 certification. This reflects our ongoing commitment to enhancing operational efficiency while reducing energy consumption, waste, and overall resource usage.



COMPLIANCE

BIM Airflow products are provided in BIM file format. Other formats ie: DWG, RFA are also available.

ErP Airflow manufactures ErP compliant fans and ventilation systems; ensuring that you are receiving energy efficient ventilation systems that perform.

WEEE Airflow Developments Ltd is registered under the Waste Electronic and Electrical Equipment (WEEE) Directive scheme.

IP Ratings Our fans are designed to meet international Ingress Protection (IP) ratings. These ratings use two numerical classifications, one for water protection and the other for dust protection.

SAP The SAP assessment incentivises low carbon developments. To help developers achieve their SAP assessment, Airflow offers a number of products and accessories with SAP eligibility.

Passive House In a drive to reduce energy consumption, Airflow produces a large range of residential and commercial MVHR units with Passive House certification. This certification means that the units use minimal energy and help to reduce energy consumption, heat loss and energy bills of the building.

Quiet Mark Airflow offer Quiet Mark approved fans. Quiet Mark approval means that the fan is extremely quiet but does not compromise on performance when in operation.

Building Regulations All of our products comply with the current Building Regulations Approved Document F Volumes 1 and 2: Ventilation (England and Wales) and Approved Document L: Volumes 1 and 2: Conservation of fuel and power. Airflow's products also comply with Scottish Building Standards, Technical Handbook 2015 for Domestic and Non-Domestic Applications, Standard 3.14 and Building Regulations (Northern Ireland) 2014, Part K.



WORKING TOGETHER

By working with professional organisations, Airflow is committed to improving the standards of regulations, product design, performance and on-site installation of ventilation products.



Building Research Establishment (BRE) is an independent organisation that is dedicated to improving the built environment and implementation of the Building Regulations.



The British Electrotechnical and Allied Manufacturers Association (BEAMA) has a specialist ventilation group that promotes best practice and installation, product specification and Building Regulations.



New London Architecture (NLA) is an independent information resource and discussion forum focused on London's built environment.



Fan Manufacturers Association (FMA) focuses on influencing and monitoring commercial and industrial fan regulations.



European Ventilation Industry Association (EVIA) assists in drafting regulations and promotes best practice.



The Residential Ventilation Association (RVA) provides a technical overview of regulations and advises on the Building Regulations.



The Kitchen Bathroom Bedroom Specialists Association (KBSA) promotes best practice kitchen, bedroom and bathroom design, which includes ventilation.



Federation of Environmental Trade Associations (FETA) represents the ventilation industry to European, U.K. governmental and regulatory bodies.



HEVAC represents the building services sector and emphasises in improving product performance and client awareness of ventilation.



TÜV is a European technical certification body that independently assesses products to EN308 standard.



VTT is a Finnish certification body that assesses products on their annual efficiency and SFP.



The Passive House Institute is an independent German research organisation that developed the Passive House standard and promotes its global adoption.



The Passivhaus Trust advocates the adoption of the Passive House standard in the U.K.



BSRIA provides specialist support for design, construction, facilities management, product testing and market intelligence in the construction and building services industry.

WHY WE NEED TO VENTILATE



AIRTIGHT HOMES

Modern dwellings are designed with increasingly reduced air infiltration rates and higher levels of insulation, making them almost completely sealed.

Consequently, the air inside your home can become moist, stale, generally stuffy and unpleasant to breathe. As we spend nearly 90% of our time indoors, we should be looking after our indoor air quality and environment much better.



MOULD

Unchecked levels of moisture and relative humidity combined with a suitable organic breeding place such as wood, carpet or wallpaper, will lead to mould growth. Mildew forms in the wall cavities and crevices and its microscopic mould spores can be inhaled. Inhaling these spores can trigger asthma, allergies and skin disorders, so extracting moist air is important.



CONDENSATION

Dampness is a huge problem in the U.K. Damaging to both humans and the fabric of buildings, condensation forms when the temperature of a surface (walls, mirrors, etc.) is below the dew point of the surrounding air. This leads to streaming windows and walls, and ultimately mould.



TOXIC GASES

A variety of noxious and toxic gases can collect within a dwelling if it's not properly ventilated. All this can have a serious effect on health and well being if not considered as part of a ventilation strategy.



CARBON EMISSIONS

Everyone is aware of the need to reduce our carbon footprint. Managing the carbon emissions from dwellings will be the cornerstone of our Building Regulations until we reach a carbon zero dwelling.

The use of low energy motors without compromising on performance is one of Airflow's contributions towards creating a carbon friendly environment.

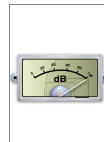

NOISE

Many people don't stop to consider the constant level of sound that they are subjected to on a daily basis.

Often it is subliminal but it remains ever present. Noise affects our nervous system and, in extreme cases, our well-being. Specifying quieter ventilation products and radial duct work, which doesn't transmit noise between rooms, contributes to a quieter indoor environment. Airflow has worked hard to reduce the noise levels on our fans without affecting their performance. Our Quiet Mark approved fans, are proof of our continuing efforts in this area.

RESIDENTIAL EXTRACTOR FANS

SYSTEM 1 Background Ventilation and Intermittent Fans

ICON®



- 3 model range with flow rate up to 84 l/s (302 m³/h)
- Timer, Humidity Timer and Motion Sensor 'snap-in' modules available
- Ductable for short runs
- Can be surface mounted or recessed
- Red Dot Design Award winning silent iris shutter prevents backdraughts
- A range of coloured covers available
- IPX4 rating
- SELV versions available
- 3 year warranty

ICONsmartⁱ



- 2 model range with flow rate up to 34 l/s (122 m³/h)
- Multi-function micro modules available for additional functionality
- Ductable for short runs
- Quiet Mark Certified with noise levels from 23.5 dB(A)
- Bluetooth controlled via myAirflow app
- IPX5 rating
- 5 year warranty

QuietAir™



- 4 model fan range with flow rate up to 72 l/s (259 m³/h)
- Timer, Humidity Timer, Motion Sensor and Variable Speed Control versions available
- Quiet Mark Certified with noise levels from 25 dB(A)
- Very low SFP and power consumption
- Long-life ball bearings with approx. 40,000 h life
- IP45 rating
- QT100 model available in black
- 3 year warranty

Aventa In-Line



- 3 model range with flow rate up to 144 l/s (520 m³/h)
- Basic and Timer versions available
- In-line mixed flow fans with 2 speed operation
- High pressure, low noise levels
- Available as a shower kit with optional LED light
- Access to motor and impeller without dismantling ducting
- IPX4 rating
- 3 year warranty

Aria



- Entry level 100mm axial fan with flow rate up to 18.5 l/s (67 m³/h)
- Basic, Timer, Humidity Timer and Motion Sensor Timer versions available
- Low noise levels from 26 dB(A)
- Can be ceiling and wall mounted
- IPX4 rating
- 2 year warranty

LOOVENT



- 2 speed filterless centrifugal fan with flow rate up to 311 l/s (110 m³/h)
- Timer, Humidity Timer and Motion Sensor Timer versions available
- Economical to operate
- Can be surface mounted or recessed in portrait or landscape
- IPX5 rating
- SELV versions available
- 5 year warranty

RESIDENTIAL EXTRACTION SOLUTIONS

SYSTEM 3 Centralised Continuous Mechanical Ventilation

Airovent



**AIROVENT
MEV WH6B**



**AIROVENT
MEV WH4B**



**AIROVENT RF
MEV WH4H**

- 3 unit range offering Whole House ventilation from a central location
- Flow rate up to 83-139 l/s (299-500 m³/h)
- All units use efficient Electrically Commutated (EC) motors
- Basic, Timer, Humidity controls
- Complies with Building Regulations and ErP
- 3 year warranty

❖ AirflexPro compatible units available, utilise the 75 mm AirflexPro with Airovent specific units



TOP TIPS

- Easy to install using 75 mm diameter Semi Rigid ducting to retro-fit your dwelling.
- New Builds with a high level of air tightness benefit by extracting a smaller amount of air continuously more often.
- Continuously running fans are virtually silent on trickle and use little energy.



Ideal solution for tenants where noise irritates. These solutions trickle at low speed in the background.

SYSTEM 3.1 De-centralised Continuous Mechanical Ventilation

LOOVENT dMEV



- Continuously running centrifugal fan
- 2 speed ventilation – flow rate up to 31 l/s (110 m³/h)
- Can be surface mounted or recessed in portrait or landscape
- Timer, Humidity Timer controls
- SELV versions available
- IPX5 rating. Complies with Building Regulations, ErP and SAP eligible
- 5 year warranty

iCONstant™



- Continuously running fan
- Quiet dMEV fan available – noise levels from 10dB(A)
- Flow rate up to 20 l/s (72 m³/h)
- Timer, Humidity Timer controls
- Guaranteed constant volume feature
- dMEV fan with IPX5 rating for walls and ceilings
- Complies with Building Regulations, ErP and SAP eligible
- 3 year warranty

iCONstant™ flex



- Continuously running fan
- Selectable trickle flow rates 18 / 29 / 40 / 47 / 58 m³/h. Boost up to 72 m³/h
- From 15.4dB(A) the quietest dMEV fan available
- Very low running cost
- IPX5 – Install in Zone 1 and 2
- Timer and Humidity versions. Two minute delay start (boost) option
- Memory retained in event of a power cut
- 3 year warranty

MECHANICAL EXTRACT VENTILATION WITH HEAT RECOVERY (MVHR)



Single unit solution

This type of ventilation is where the existing air in the property is extracted, as it is extracted the heat is removed (recovered). Then the unit uses this heat to warm up the new fresh air entering the property. So giving you consistent fresh air that is warmed up using the recovered heat.

There are various solutions available:

Single room MVHR units, these are units that are installed in each room. They can be used in isolation in Wet rooms (ensuite, bathrooms, utility and kitchens) or can be used in habitable rooms (bedrooms, living rooms, dining rooms, home office).

Factors that need to be considered when using these units is the amount of background ventilation available and that they need to go on an external wall.

You can also use single units as a total house solution, this is done by pairing units up and is very useful for where retrofit does not easily allow for a central MVHR unit to be installed.

Central room MVHR units, these are for the whole house solution where they supply and extract air for the whole dwelling using one central unit. With central supply & extract you would need to use ducting

to reach each of the rooms.

Airflow have central solutions where units can utilise space that is not always optimised, above a hob in the kitchen is such an area, we have combined a MVHR unit and an extractor hood together. This unit is ideal for apartments where storage space is of a premium. Another such space is above the front door, we have units that can be placed above the front door and the filters accessed from outside, so no need to disturb the occupiers for any filter changes and maintenance.

Multi room extraction with Heat Recovery

Habitable room solution, can also be combined to provide a total dwelling solution

Unohab



- | Lots of flexibility with low noise levels
- | EC Motors and built in filter
- | Can be connected to other units to provide total house solution
- | Can be connected to extractor fans in wet rooms to ensure correct air volumes of air are extracted when fans are in use
- | Systems can be designed to meet Part F System 1 or 3.1
- | Used in retro fit or new build
- | Used in Multiple Occupancy Properties
- | Accessories that enable for the extract to be incorporated into properties with external wall insulation
- | Suitable for various wall depths



MVHR SINGLE DWELLING UNIT EXAMPLES



1 bed maisonette

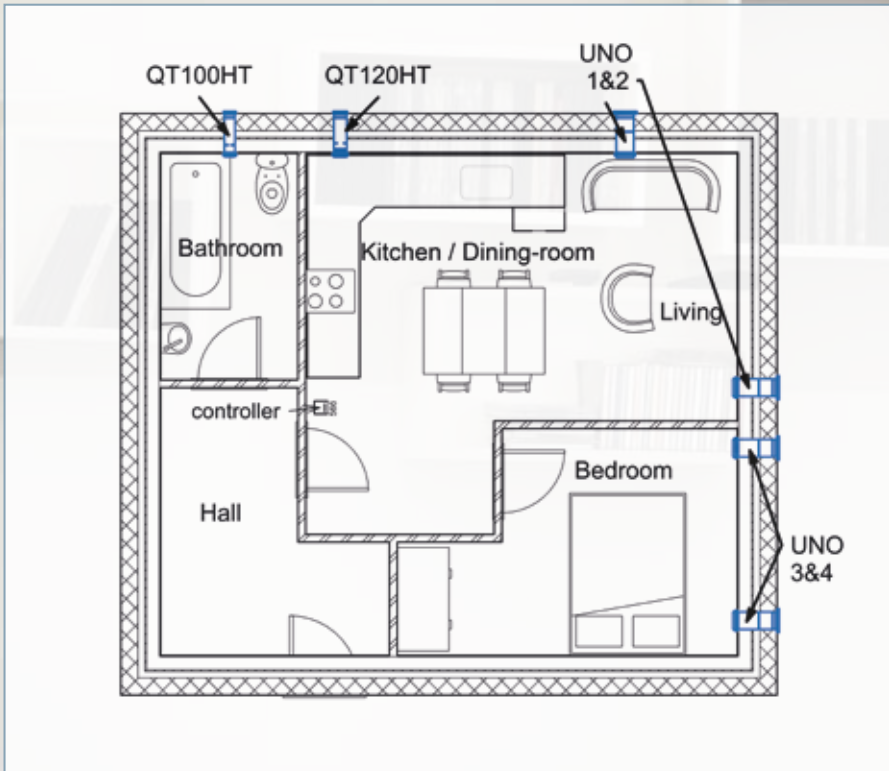



Two examples of where UNO has been used to provide an MVHR solution to a total dwelling.

They have been combined with QuietAir to provide a total system, so that the correct extraction rates are achieved to meet building regulations.

By using a control unit the UNOhab units communicate with the QuietAir extractor fans. When the QuietAir is activated in the wetrooms, the UNOhab switches to supply air only, ensuring there is enough replacement air entering the dwelling so the moist humid air can be removed.

KEY

-  UNO
-  QuietAir

2 bed maisonette

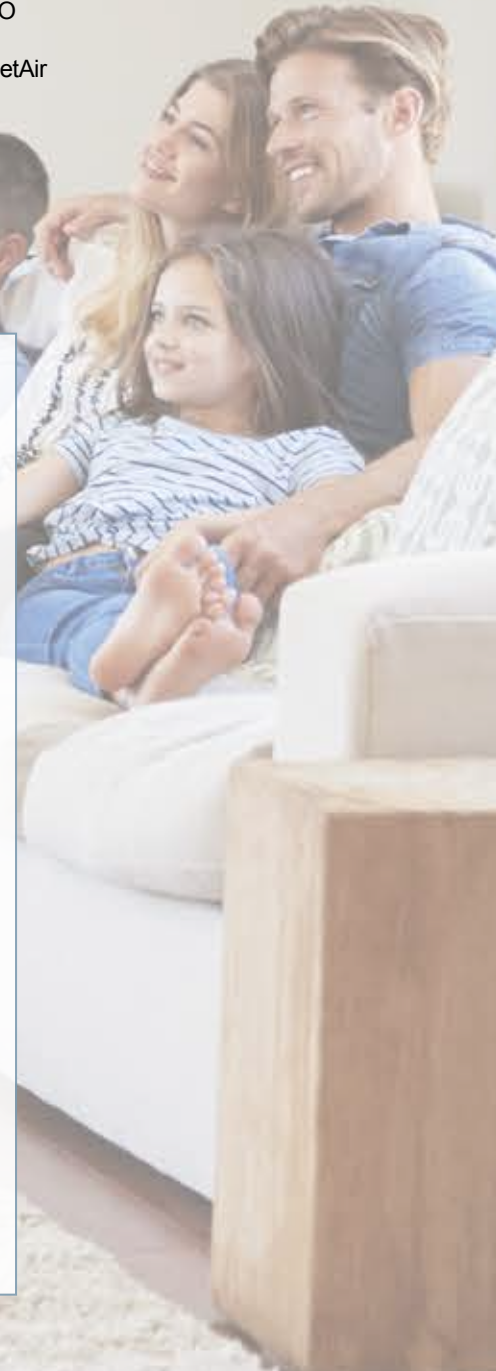
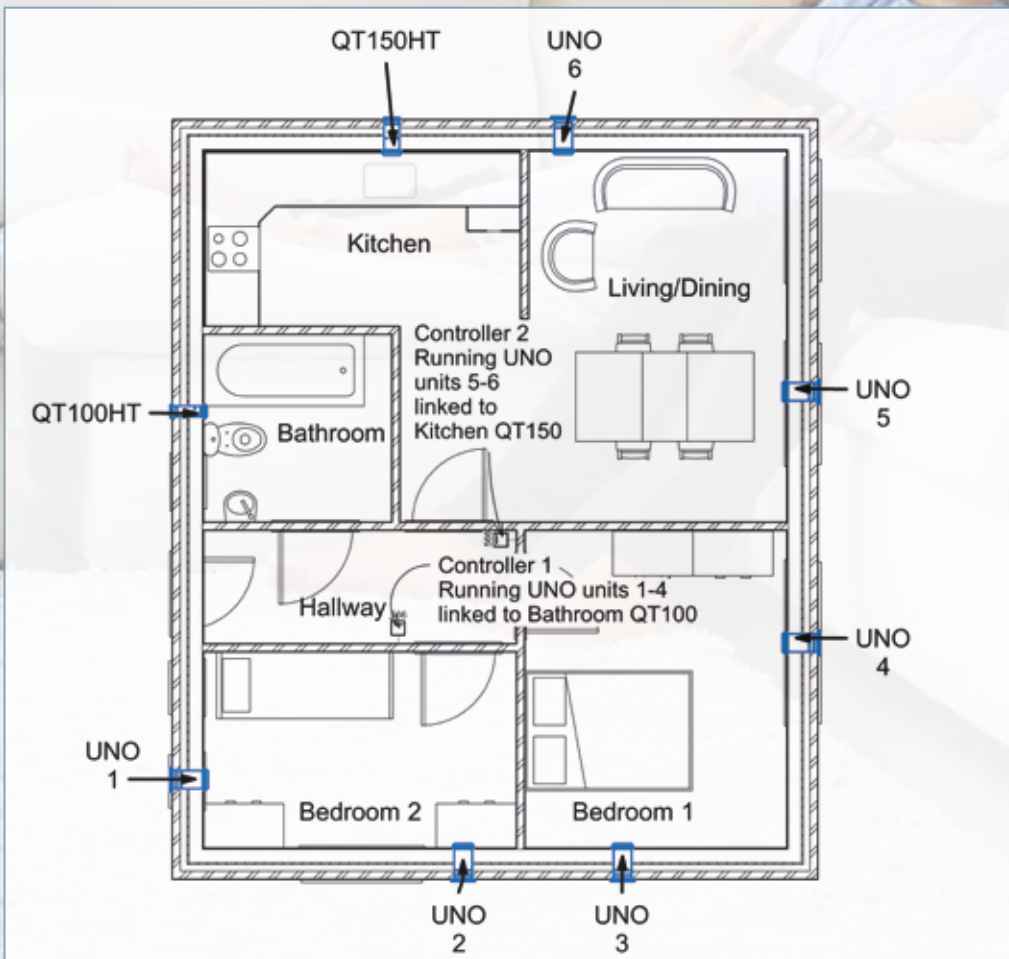

INTERNET CONTROLLED SOLUTIONS



Central unit solutions

A Ventilation Unit with a Cooker Hood - Small Apartment Solution



Adroit™

Combines ventilation and extraction of cooking odours in the kitchen

- | Flow rate up to 47 l/s (170 m³/h) at 100 Pa
- | Up to 84% thermal efficiency
- | Full heat recovery for whole dwelling
- | Recovers heat from the hob
- | Slim and stylish extractor hood
- | Internet control
- | Integrated into the kitchen unit
- | 5 years warranty*



*excludes motors. Motor warranty one year from date of purchase.

Adroit Space Saver



Adroit™



- | Suitable for dwellings up to 120m²
- | Flow rate up to 93 l/s (225 m³/h) at 100 Pa
- | Up to 90% thermal efficiency
- | Remote "on the go" Internet and BMS control available
- | Unique triple filter facility including an ePM1 50% (F7) pollen filter
- | Available in left and right-hand models
- | Complies with Building Regulations, SAP recognised, ErP and Passive House Institute certified when fitted with integral electric heater
- | Integral carbon dioxide and humidity sensors as standard
- | 5 year warranty*

EASILY ACCESSED FROM OUTSIDE THE PROPERTY

The Adroit has been designed to fit within a ceiling void. This means that Landlords can protect their investment by insuring planned maintenance from outside the dwelling. This preserves the building fabric, ensures occupier wellbeing and saves energy without the need to access the property or disturb the tenant.

Easy access to replace filters

Heat Recovery

Removable, secure front cover panel for maintenance

Removable Heat Exchanger for quick cleaning

Durable steel double skin casing with 20mm insulation



*excludes motors. Motor warranty one year from date of purchase.

INTERNET CONTROLLED SOLUTIONS

Adroit - top entry



Adroit®



- Range suitable for dwellings up to 400 m²
- Flow rate up to 258 l/s (929 m³/h) at 100 Pa
- Up to 93% thermal efficiency
- Remote "on the go" Internet and BMS control available
- Unique 2 x G4 and 1 x F7 air filter system
- Range available in left and right-hand models
- Complies with Building Regulations, ErP and Passive House Institute certified when fitted with integral electric heater
- 5 year warranty*
- Accessories include CO₂ sensor, VOC Sensor, post heater
- No thermal bridging
- 20 mm insulation cased between powder coated casing panels
- 7 Adroit units to choose from
- Smart frost protection
- Remote access for fault diagnosis
- 7 day programmer
- Auto cut off switch when filters are changed

*excludes motors. Motor warranty one year from date of purchase.

Remove harmful incoming pollutants

Inner city solutions - High efficiency NO_x filters

Nitrogen Oxide (NO_x) pollution, with other chemicals is linked to 40,000 premature UK deaths a year and is particularly prevalent in areas with heavy traffic such as industrial areas, busy roads and outside schools.

If you are living in a built-up area, it is important to ensure that you incorporate a NO_x filtration system as part of your wider ventilation system.

Airflow's NO_x filtration system works in conjunction with the unit's air filters to remove harmful air pollutants from the incoming air before it is distributed around the dwelling.

By ensuring that the incoming air is at healthy levels, you ensure that health and well-being of those inside is protected as well as improving persons concentration levels.

- Filters particulate matter and gases to remove pollutants prior to the air entering buildings
- Additional filtration system above the air filters within the MVHR unit
- Filters up to 90% of harmful NO_x particles out the incoming air
- Improves the indoor air quality
- Variety of sizes available to fit your MVHR unit



DUCTING SOLUTIONS

Retro ducting system

This versatile and innovative ducting is designed around a coving system that can be incorporated within the visible part of the house or flat and is ideally suited to a standard footprint building design where there is a common entrance hallway with all the rooms branching off the hallway.

Retro ducting is lightweight, versatile and easy to fit making it the perfect choice for a discreet coving ducting application. This system can be used for System 4 (Mechanical Ventilation with Heat Recovery) in a supply and extract function and also System 3 (Mechanical Extract Ventilation) as an extract only duct system.

Discreet coving air ducting ideal for renovations



- | Discreet, quick to install air ducting for MVHR systems
- | Designed for both new build and renovation projects
- | Easy installation in 3 steps
- | Coanda effect supply valves enable good circulation without the need for longer ducts
- | Suitable for standard footprint building design
- | Can be painted to suit inside décor of dwelling
- | Negates the need for suspended ceiling to hide the ducting system
- | Fire retardant to eu-b2 rating DIN 4102

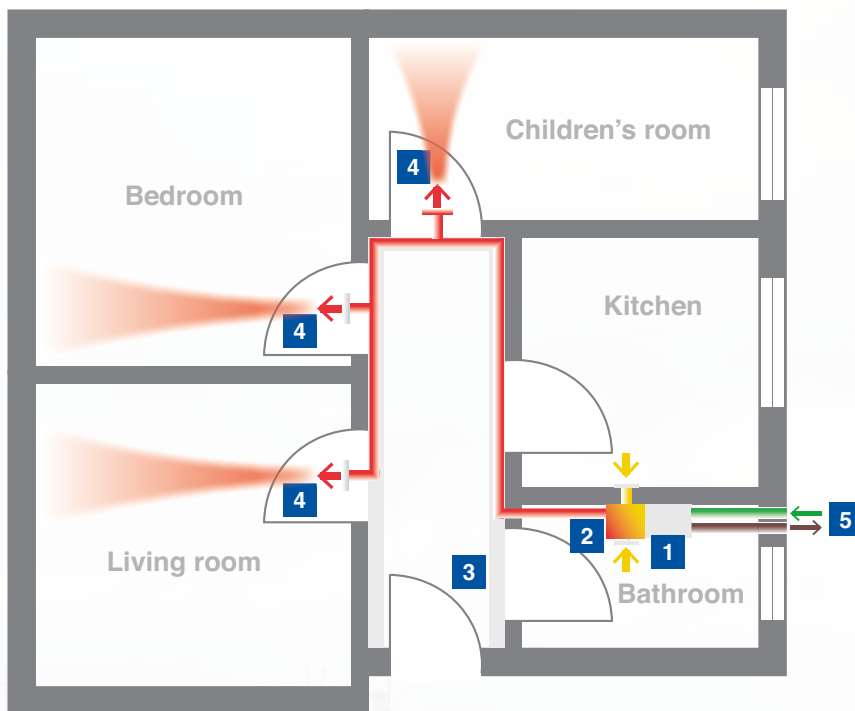

- = Supply Air to habital rooms
- = Intake Air from outside
- = Extracted Air from wet rooms
- = Exhaust Air to outside

1. MVHR unit
2. Distribution box
3. Retro ducting
4. Coanda valves above door
5. Intake and extract

So easy to fit



Step 1



Step 2



Step 3

DUCTING SOLUTIONS



Coanda Air Valve - Works well with Retro ducting

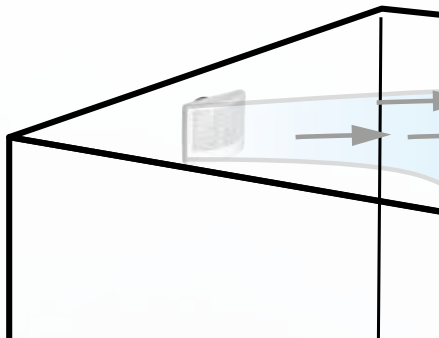

When coanda valves are used with Airflex Retro, it removes the need for the valves to be located in the corner of the room. Therefore making installation that much easier.

Coanda valves supply air into a habitable room more effectively than conventional air valves. By directing a low pressure jet of air from a high level valve the air flow attaches itself to the ceiling and remains attached for a longer distance, thereby increasing the "throw" of the valve.

Using Coanda valves enable a greater more even distribution of air throughout the room having more positive effect on the internal atmosphere.

Coanda Valves can also be used as conventional extract valves for whole house balanced ventilation systems.

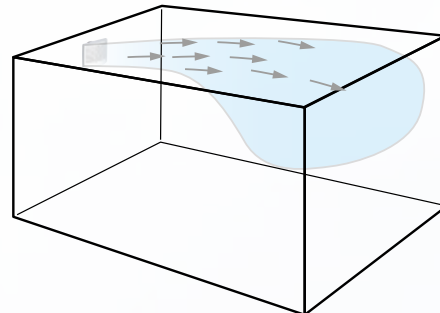

AIRFLEXPRO

Semi rigid ducting

A quick and easy to fit system of semi-rigid ducting that can result in up to 70% time saving during the on-site installation process, compared to rigid or spiral duct methods.

This innovative system uses low resistance and antibacterial smooth round and oval tubes which connect each room to the heat recovery or ventilation unit via an air distribution box.

The AirflexPro Oval ducting is designed to equal the hydraulic performance of AirflexPro Round so both types can be used within the same system without a loss of performance.

Semi rigid ducting without joints. Performance data is now recognised by the U.K. Government as an input for Standard Assessment Procedure (SAP) calculations via SAP eligible.

Mix and Match, "Oval or Round" = No Loss of Performance



- | Zero leakage ensures highest performance
- | Fire rated to EN13501-1 Class E
- | 70% time saving on installation
- | Interchangeable ducting system (75 mm round / 51 mm x 114 mm oval) without any hydraulic pressure loss
- | Compact, suits narrow joists and low ceiling voids
- | Durable with high crushability (10kN/m²)
- | Smooth bore with antistatic and antibacterial lining
- | Easy to clean when installed
- | SAP eligible ducting (non-jointed)

AirflexPro Round



AirflexPro Oval



Loovent

The Powerful Performer



Versatile and Reliable
More than 1,500,000 sold!

The 4th generation of the Million Plus selling Loovent extractor fan. With a pedigree of proven reliability and outstanding performance it really is a fan for all applications.

Airflow *up to 31 l/s*

Power *from 2.8 W*

Quiet *from 25 dB(A)*

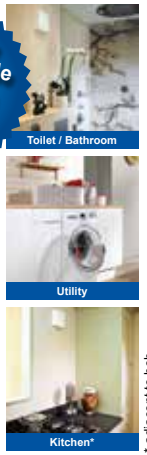

* adjacent to hob

Many options – A Fan for all reasons

Intermittent Loovent T

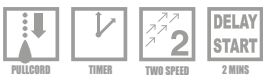

Loovent HT



Loovent MST



Intermittent SELV Loovent SELV



Loovent SELV HT



Continuous dMEV Loovent dMEV T

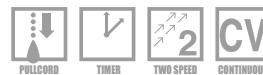

Loovent dMEV HT



Continuous SELV dMEV Loovent SELV dMEV T



Loovent SELV dMEV HT



Why Choose Loovent? Experience makes the difference

- Two speed - intermittent & continuous models
- Longer lengths of ducting no problem. Delivers 15 l/s through 6 m of flexible duct
- Sound pressure levels as low as 25 dB(A) at normal operation
- For New Build and Social Housing upgrades
- Energy efficient DC motor, from just 2.8 W standard
- Surface or recessed, portrait or landscape, wall or cavity
- IPX5 rating for both wall and ceiling install
- The smallest footprint in its class
- Quick and easy to install, proven over four decades
- Fast to fit and interchangeable with older versions of Loovent 01C and 01 Fans, same mounting holes and outlet position
- At least 40,000 hours constant operation
- No noise magnetic anti-backdraught flap
- Anti-strangle pull cord, electrical cut out when cover removed
- Made of 100% recyclable materials
- Complies with latest Building Regulations requirements
- 5 year warranty

Suitable for New Build and an easy upgrade from old Loovents

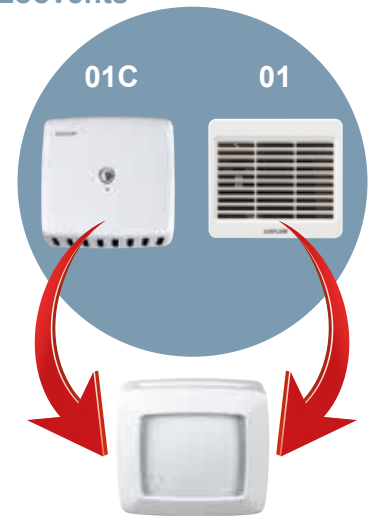

- Same mounting holes
- Same outlet position

Bezel available for neat finish

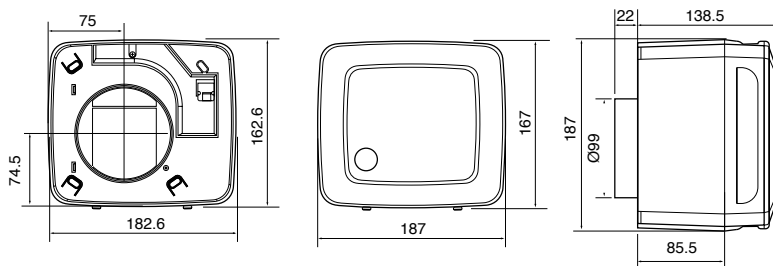

NOT ALL SYSTEMS ARE AS EFFECTIVE



Considering Positive Input Ventilation (PIV)?

A system originally developed in the 1970's for leaky Victorian houses continues to be chosen as a "Quick Fix" for some Social Housing upgrades.

However, as new homes are built to a better standard and renovations include significant insulation, there are few factors to be considered.

Perception can be misleading

The actual drawbacks of PIV are that the air displacement principle can only work on leaky buildings as there is little control over where the air goes.

Not as suitable for well insulated new build properties where there are definitely fewer

leakage paths.

Poorly insulated ceilings allow humid air to rise into the loft space, which means the damp air is re-circulated again.

Much loft space air is not "fresh" as it is subject to other airborne construction material contaminants.

Difficult access to filter for routine cleaning / replacement. In tenant properties they will never do it, so is there a landlord replacement schedule?

To avoid frost damage to the unit and to warm up in cold air in an uninsulated loft space in winter, a costly (24 / 7) electric heater is used warm up incoming cold air.

If a heater is not used, cool air (i.e. a draught) is forced into the hallway / stairs

dropping the temperature in those areas.

Noisy. The joist mounted fan is a short distance from the ceiling input diffuser. Transfer grilles may be needed in doors to rooms which do not open directly on to the hallway.

Older properties won't have been built with a 10mm gap undercut to internal doors. Consequently air circulation, condensation, dampness and mould issues are not addressed in these rooms.

Possible noise / vibration issues from units screwed to ceiling joists. Unit runs continually so creating a constant sound.

Is the loft space really a source of ventilation air you want to use? Relying on an air filter to condition contaminated air seems dubious.

More critically

PIV forces damp, moist air into the fabric of the building through the wall sockets, into wooden windows, through vents and gaps in the floor boards, contaminating plaster and insulation materials with humid air.

When an occupant opens a window they will create a path of least resistance nullifying the positive pressure in the dwelling which the device is designed to maintain and thereby creating a condition where the damp, moist air in the wet rooms will not be removed.

Does it work?

PIV is not recognised as one of the four primary approved ventilation systems by the Building Regulations, Approved Document F1, 2010 (amended 2013) Means of Ventilation. In fact this methodology was removed from the Building Regulations Approved Document F list of approved systems in 2006 because of doubts about its effectiveness and performance issues.

- | Introduces loft air into the dwelling.
- | Positively pressurises the inside of the dwelling to create air or circulation by forcing damp air to escape through existing gaps,vents,floorboards,windows and cracks.
- | Condensation is supposedly eliminated as the damp, moist indoor environment is reduced with filtered (but hardly fresh) air from the loft.

How do you test the efficiency of a PIV installation?

- | The Building Regulations require that 'notifiable work' ie: repairs, maintenance and upgrades/improvement that require planning permission require sign off by Building Control. Similar to new build installations, prescribed ventilation rates as documented in Building Regulations Approved Document F and are required to be measured, recorded and submitted to the local authority Building Control.

- | But how do you measure the effective circulation of a device which blows air into a leaky dwelling? Without a whole house leakage test who knows how much the dwelling is leaking?

- | Approved extract systems 1,2,3 and 4 can be accurately measured with a Powered Flow Hood to determine air flow rates. Drawing air from a loft space and pumping it into a dwelling which may not have open path ways (ie: undercuts to doors)to the wet rooms and then relying on the moist air to leach out of cracks or vents in the dwelling is much more difficult and adds a huge element of uncertainty.



VENTILATION MATTERS

Protect the health of your tenants
and the fabric of your property

Ineffective ventilation can lead to mould and condensation, resulting in poor air quality that affects people's health and damp conditions that threaten the value of your investment. The good news is that the solution's a simple one. We are experts in ventilation systems and have high-quality, low maintenance products for all types of rental and social housing.



www.airflow.com

AIRFLOW 



Explore the house to discover what could be making you ill...

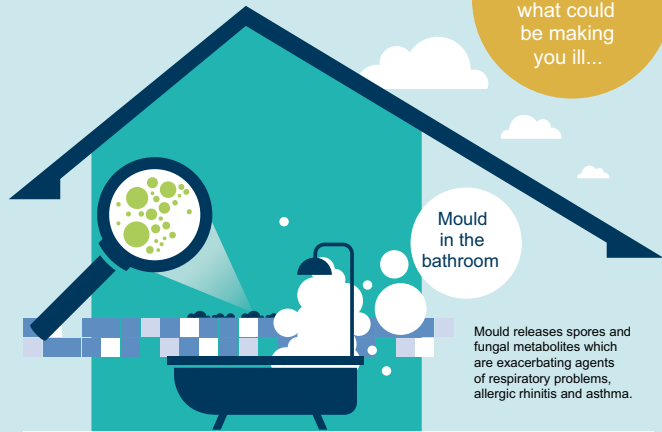

Mould in the bathroom

Mould releases spores and fungal metabolites which are exacerbating agents of respiratory problems, allergic rhinitis and asthma.

Volatile organic compounds (VOCs) can irritate the lungs. Acetaldehyde and benzene, two VOCs washing gives off, are carcinogens. Most of the VOCs can't be traced to any particular ingredient in the detergent.



drying washing inside

wood burning fireplaces

Particle pollution in smoke can damage lung tissue and lead to serious respiratory problems when breathed in high concentrations.



Carpets harbour dirt, dust mites, pet hair, fungus and other potentially harmful particles that can aggravate the lungs, trigger asthma attacks or send some people into allergic fits.

carpets

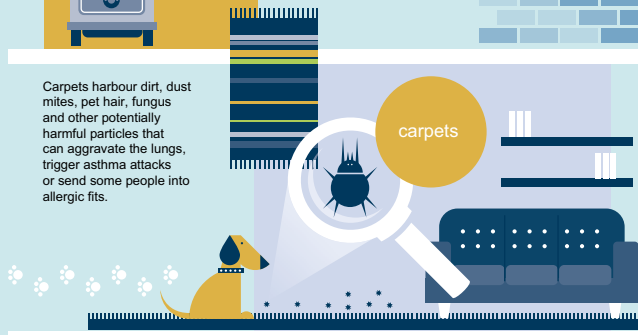

Cooking on a gas hob gives off nitrogen dioxide, acrolein, formaldehyde and carbon monoxide. These have been linked to respiratory symptoms and cancer.

cooking with gas



Paints release volatile organic compounds that may have a range of subtle health effects if breathed in over a long period of time.

paints

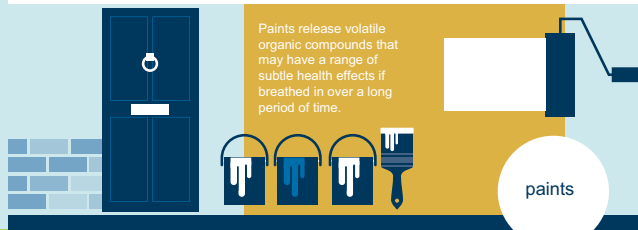

EXPERT ADVICE

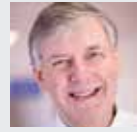

Peter Howarth, Professor of Allergy and Respiratory medicine at Southampton University, calls for increased awareness of what is being termed 'Toxic Home Syndrome'.

"Toxic Home Syndrome occurs when individuals and families are exposed to a potent mix of airborne pollutants within the home arising from poor ventilation, causing respiratory and skin diseases to occur more frequently.

I have had many patients come to me with serious respiratory conditions due to pollutants within the home. With respect to asthma, mould allergy is recognised to be associated with worse asthma and poorer asthma control. The presence of moulds within the home is a reflection of poor ventilation and increased humidity. Homes with mould are also likely to have higher house dust mite allergen levels and this may worsen both respiratory and skin conditions. The lack of adequate ventilation within the home can also be associated with the build up of non-allergenic noxious fumes which are detrimental to health."



THE EFFECTS OF POOR VENTILATION

- Nearly 90% of asthma sufferers are allergic to allergy DER P1 which is present in House Dust Mite droppings
 - HDM require high humidity - typically over 70% to live and reproduce
- It is clear that lowering humidity levels will help to keep HDM colonies in-check and thereby reduce the incidence of asthma attacks

WHY DO WE NEED VENTILATION?

Ventilation is required for...

- Provision of fresh air for breathing
- Dilution and / or removal of airborne pollutants and odours
- Controlling excess humidity arising from water vapour in the indoor air
- Provision of air required by fuel burning appliances

MOISTURE PRODUCTION?

A family of 4 produces up to 14 litres (24 pints) of moisture per day:

- Bathing & Showering
- Washing & Drying
- Cooking
- Breathing



Fan selection software

SELECTair

airflowselectair.co.uk

Airflow Selectair selection software allows the user to select products from our Domestic, Commercial and Industrial fan ranges and also select from our Heat Recovery range suitable for their

application. The software is hosted within the Airflow website.

Selectair software has been designed to ensure that products are

selected to fulfill the requirements of your application. By following a logical and easy to use sequence fans are listed which are suitable for the room of your choice, through the wall or ducted installation and the type of ducting you will be using.

By automatically calculating the pressure drop values for your requirement, a choice of products are linked to ensure "installed performance" criteria is met. This gives the specifier the confidence to know that choosing a fan from the products offered will deliver the performance expected to meet the latest building regulations for fast, effective ventilation.



Technical



We have a fully trained technical team in our UK head office and in the field, that can provide assistance and application advice on all ventilation matters. From choosing a residential extract fan to specifying a commercial MVHR system.

System design



If you are considering specifying a ventilation system why not send us your drawings. We can advise on the most suitable product complete with compatible accessories to ensure an effective installation.

Send your drawings to: plans@airflow.com

BIM

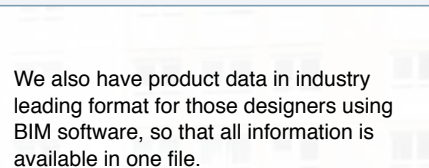

We also have product data in industry leading format for those designers using BIM software, so that all information is available in one file.

Airflow's BIM models adhere to criteria required by the following BIM standards: IFC, COBie, RIBA, CIBSE

Airflow also provides you with bespoke information not covered by these standards, such as ErP data and whether a product is Passivhaus approved.

Airflow's BIM models are compatible with Revit 2015 and newer. The models are available Revit 2015 as standard and will automatically upgrade to the user's version of Revit upon first use.

airflow.com/BIM

Product Resellers



Scan the QR CODE to find resellers available.

FIELD SUPPORT

Field support



Airflow do not view our customers just as a short term arrangement. We believe that by working together in partnership we can achieve better results in realising our shared objectives to deliver efficient, effective and reliable ventilation solutions so that you and your tenants are living in a healthy environment.

Our knowledgeable, trained technicians can provide support to ensure your ventilation projects run smoothly and where issues arise they can advise on the most suitable course of action to provide a successful outcome.

Airflow offers full field support across the UK, our after sales team can deal with any post sale needs and requirements. For any pre sale needs and requirements then our technical sales team can assist.



Contact us



Airflow Developments Limited

Tel: 01494 525252
e-mail: info@airflow.com

Customer Services

Tel: 01494 560800
e-mail: customer_services@airflow.com

Technical Support

Tel: 01494 560950
e-mail: technical_sales@airflow.com

Sales

Tel: 01494 560800
e-mail: sales@airflow.com

Airflow Developments Limited
Aidelle House, Lancaster Road,
Cressex Business Park,
High Wycombe, Buckinghamshire,
United Kingdom, HP12 3QP

airflow.com





UNITED KINGDOM (head office)

Airflow Developments Limited
Aidelle House, Lancaster Road
Cressex Business Park
High Wycombe, Bucks. HP12 3QP.

Tel: +44 (0) 1494 525252
Email: info@airflow.com
Web: airflow.com

GERMANY

Airflow Lufttechnik GmbH
Wolbersacker 16
53359
Rheinbach, Germany

Tel: +49 (0) 2226 92050
Email: info@airflow.de
Web: airflow.de

CZECH REPUBLIC

Airflow Lufttechnik - Praha
Hostynska 520
10800 Praha 10
Prague, Czech Republic

Tel: +42 (0) 2747 72230
Email: info@airflow.cz
Web: airflow.cz